

Easter is the oldest and most important Christian festival, marking the end of the fasting season of Lent and the death, on Good (derived from God's) Friday and resurrection of Jesus Christ, on Easter Sunday. There are many customs and traditions associated with Easter which, like most other holiday and feast days, are derived from a combination of both Jewish lore and pre-Christian and pagan practices. It is named after Eostre, the goddess of fertility and birth, worshipped by first-century pagans at the vernal equinox, who believed she would bless both their families and their crops. Christian missionaries saw this celebration took place around the time of the resurrection of Christ, so they adopted Easter as a Christian holiday to increase conversion.

Easter



the Seder meal, which traditionally marks the start of Passover. A slightly less painful experience, it is also called Holy Thursday or Great Thursday, in the Orthodox world. It marks four key events - the washing of the feet of the disciples by Jesus Christ, the institution of the Last Supper, the agony of Christ in Gethsemane and the betrayal by Judas Iscariot. Maundy, the British name, derives from the Latin "mandatum", the first word of the Latin translation of the statement by Jesus explaining to The Apostles the significance of the washing of their feet: "A new commandment I give unto you, That ye love one another; as I have loved you."

Eggs, of course, are ancient symbols of fertility, for very obvious reasons, while the Seder meal incorporates a hard boiled egg as a symbol of new life. An egg has also been seen to be associated with the rebirth or resurrection of Christ. The custom of eating them also derives from the fact that they were forbidden during Lent. There are a great many rituals associated with eggs, mainly dating from Mediaeval times in Europe, usually involving decorating, throwing, rolling or hiding eggs for children to find them.



Some of the early Christians debate the desire to keep the date of Easter separate from the week-long Jewish festival of Passover, which celebrates the Exodus and freedom of

the Israelites from ancient Egypt. It is believed that the Last Supper was in reality

From The Pastor

Greetings in the Name of Christ,

Over the last few weekends I have been to three different seminars on worship and have been introduced to some different ideas and forms of worship. I have been brought up in the Methodist church and like all Methodists we were taught to sit on our hands and smile as loudly as we could during our worship services. What is the definition of worship? When George Barna surveyed church-going people and asked what worship was, most people don't really know what worship is. What is worship? Worship does have a biblical understanding: worship honors God and is directed toward God and requires involvement. ("and they bowed their heads and worshiped the Lord with their faces to the ground" Nehemiah 8:6 – "and they came up and took hold of his [Jesus'] feet and worshiped him" Matthew 28: 9) Worship does require involvement! Worship is a verb. We need to worship in spirit and truth. (The woman said to him, "Sir, I perceive that you are a prophet. Our fathers worshiped on this mountain, but you say that in Jerusalem is the place where people ought to worship." Jesus said to her, "Woman, believe me, the hour is coming when neither on this mountain nor in Jerusalem will you worship the Father. You worship what you do not know; we worship what we know, for salvation is from the Jews. But the hour is coming, and is now here, when the true worshipers will worship the Father in spirit and in truth, for the Father is seeking such people to worship him. God is spirit, and those who worship him must worship in spirit and truth." – John 4: 19-24) To worship in spirit, then, means to engage the inner self. Not just going through the motions, but a true heart response to God. Routine can be – is not necessarily, but can be – the enemy of true heart-felt worship. Jerry Bridges in his book, *I Exalt You, O God*, said: "Without the heart, it is not worship; it is a stage play, an acting part... We may truly be said to worship God, though we lack perfection; but we cannot be said to worship Him if we lack sincerity." Someone suggested that we should have a reality meter in our worship services so that we can find out if we really mean the words we say and sing. We often substitute our traditions – "This is the way we have always done it". Are we worshipping in truth? Not in emotionalism, but in true, heartfelt worship from the depths of our being? "And you shall love the Lord your God with all your heart and with all your soul and with all your mind and with all your strength" (Mark 12:30) Now that's not passive! So what does the Bible say about worship? Psalm 46:10 – "Be still, and know that I am God..." , Psalm 47: 1 – "Clap your hands, all peoples!" , Psalm 66:1 – "Shout for joy to God..." , Psalm 96: 1 – "Oh sing to the Lord a new song..." , Psalm 134:2 – "Lift up your hands to the holy place and bless the Lord" (also Psalm 63:4), Psalm 149:3 – "Let them praise his name with dancing..." , Psalm 150: 3-5 – "Praise him with the trumpet sound...the lute and harp...tambourine...strings and pipe...cymbals. Our worship is for God and must be spirit and truth, as both are essential. If it is just spirit our worship is completely experiential with no solid foundation. Just truth and our worship becomes ritual without sincerity. This Easter let us turn our lives around and worship God and the resurrection of His Son, our Lord and Savior, Jesus Christ with truth and spirit.

Shalom

Dean

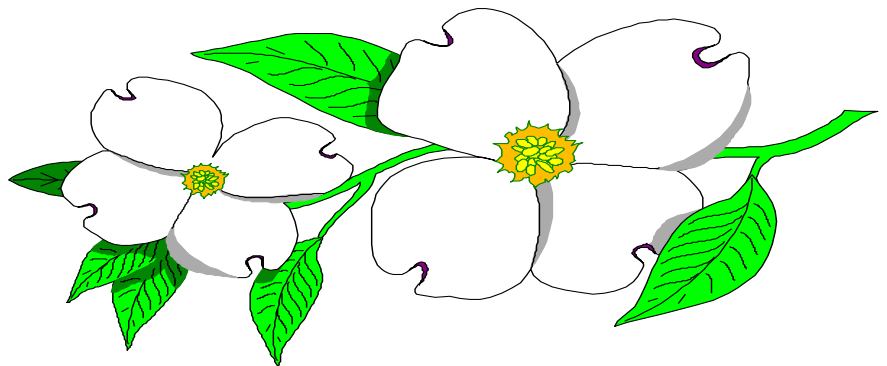



Social Justice

Recently, a popular talk-show host expressed his opinion that the words, “social justice,” were code words for communism or fascism. He encourage his listeners to leave their church, if those words were found on the church’s website. The United Methodist have a pamphlet titled, “United Methodist Social Justice Stands.” It states:

The United Methodist Church has a long history of concern for social justice. This history has its roots in John Wesley’s admonition to reform the continent and to spread scriptural holiness across the land.

Our founder, John Wesley, along with his brother, Charles, and a few other friends at Oxford University in the 1730’s, began taking seriously Jesus’ words about feeding the hungry, visiting the sick and those in prison, giving drink to the thirsty and clothing the naked. They went to the prisons and jails where they talked with the inmates and did what they could to ease their suffering. The Methodists started Sunday Schools for the children who worked in the factories, and who could not afford to attend school; and they eventually went on to establish an orphanage. They supported cottage industries, and they even developed a short-term loan assistance program. They established patterns of visiting the elderly and sick, and that has continued to be a vital part of our ministry.

Today, United Methodists support agencies such as the United Methodist Family Services, the Henry Fork Center, and the United Methodist Committee on Relief, among many others. We stand for justice in many different ways, including lobbying for laws which protect the “least” in our society, and we speak up for those who have no voice. United Methodists are proud of our heritage of Social Justice, for we believe that when we stand for Justice, we demonstrate the love of God as seen in the life of Jesus.

As we enter the season of Easter, may our spirits be renewed as our faith is strengthened, and may we resolve to celebrate the resurrection of Christ as we stand for justice in ways large and small, here in our community and throughout the world.

Rev. Mary Ann

Note: There are several copies of “United Methodist Social Justice Stands” in the Narthex. Please help yourself. Let me know if we need more.

April Communion Offering:

Our communion offering for April will benefit **Lakeside Volunteer Rescue Squad**.

For the past 50 years, Lakeside Volunteer Rescue has provided free emergency care 24 hours a day, 7 days a week. The organization continues to grow and their mission has not



changed in the passed 50 years.

This emergency service is provided by trained individuals who willingly give of their time and energy to provide emergency care to those in need. This is at no charge to the individual.

Measuring Cup clean-up: Before you pour sticky stuff into a measuring cup, fill with hot water. Dump out the hot water, but don't dry the cup. Next, add your ingredient, such as honey or peanut butter. Watch how easily it comes out.

Broken Glass Clean-up: To clean up broken glass, use a wet cotton ball or cotton tipped swab to pick up small shards you can't see easily.

The Willing Workers

The Willing Workers circle will meet at 7 p.m. in the home of Charlene Hawkins on Wednesday, April 7. We will continue to work on our plans to collect items for the troops overseas. Anyone is welcome. Please call Glenda Stalnaker at 804-755-6767 for more information.

Church Family Birthdays and Anniversaries

Our birthdays for April are:
Arline Shafer - 4/1, Joan Sipe - 4/8, Kenny Sipe - 4/23, Lavelle Sheffield - 4/19 and Carolyn Smith - 4/12. **Happy Birthday Everyone.**

Our anniversaries for April are: Charlene & Maurice



Hawkins - 4/10, Hugh & Betty Lloyd - 4/15, Steve & Tara Morgan - 4/9, Joan & Kenny Sipe - 4/8 and Glenda & Steve Stalnaker - 4/10.

Methodist Minute

Membership – When persons have asked to join in membership into the Methodist church after professing their faith, either by confirmation, transfer of membership or through baptism they are asked the following: Will you be loyal to The United Methodist Church, **and uphold it by your prayers, your presence, your gifts, and your service?** As members, do we take this responsibility seriously? Every church has a number of persons on church roles that do not fulfill their vows of membership and Greenwood is no exception. At the time these persons are received into the church, the congregation is also given a charge and accepts their responsibility. The congregation is asked to: Do all in your power to increase their faith, confirm their hope, and perfect them in love. The congregation responds: With you, we renew our vows to uphold it by our prayers, our presence, our gifts, and our service. With God's help we will so order our lives

after the example of Christ that..... We claim to be members of the church and are being faithful to God with keeping our vows. (Reception into the United Methodist Church, Reception into a Local Congregation: The United Methodist Hymnal)



Received in an email:

They say that the average size woman in America is a size 14. The funny side of me wants to ask, "So who wants to be below average?" and the more reasonable side of me asks, "If you are healthy and active, what difference does the number on the tag of your pants make?" But let's face it, When it comes to our bodies, circumnavigating all the messages we receive in our culture are not for the faint of heart.

I will never forget a comment I heard from a fashion designer several years ago. He said that the fashion industry is all about the clothes, not the people wearing them and that the best way to highlight the

clothes is to drape them over a "human hanger" rather than an actual person whose curves would interrupt the lines of the design.

I bought a blouse the other day. It was hand beaded, striking, and beautiful (and on sale!). But I was as taken by the message on the hanging tag as I was with the blouse. It read: "I am your special garment. I am unique and often hand-woven, hand-beaded, hand-printed and hand-painted. My defects are part of my beauty!" If only we came with such a tag.

Written by Anita Renfroe

God looked over all that he had made, and it was excellent in every way. - Genesis 1: 31.

The Quiet Sermon was sent to me by email; it spoke to me; I pray it will speak to you. If this applies to you, then hopefully, it will bring a positive change in your life.

The Quiet Sermon

A member of a certain church, who previously had been attending services regularly, stopped going. After a few weeks, the preacher decided to visit him.

It was a chilly evening. The preacher found the man at home alone, sitting before a blazing fire. Guessing the reason for his preacher's visit, the man welcomed him, led him to a comfortable chair near the fireplace and waited. The preacher made himself at home but said nothing. In the grave silence, he contemplated the dance of the flames around the burning logs.

After some time, the preacher took the fire tongs, carefully picked up a brightly burning ember and placed it to one side of the hearth all alone. Then, he sat back in his chair, still silent. The host watched all this in quiet contemplation. As the one lone ember's flame flickered and diminished, there was a momentary glow and then its fire was no more. Soon it was cold and dead. Not a word had been spoken since the initial greeting. The Preacher glanced at his watch and realized it was time to leave. He slowly stood up, picked up the cold, dead ember and placed it back in the middle of the fire. Immediately it began to glow, once more with the light and warmth of the burning coals around it.

As the preacher reached the door to leave, his host said with a tear running down his cheek, "Thank you so much for your visit and especially for the fiery sermon. I shall be back in church next Sunday."

We live in a world today which tries to say too much with too little. Consequently, few listen. Sometimes the best sermons are the ones left unspoken.

United Methodist Men

The Greenwood UMM will have their monthly breakfast meeting in the Fellowship Hall on April 3.

The cooks and the program are yet to be determined. All the men of the church are invited to attend - just let Roger or Charley know you are com-



ing so there will be enough food.

The next litter pick-up along Greenwood road will probably be June 5 unless it looks like it needs it by May 1. Everyone in the church over 18 years old is invited to help with this project.

Greenwood's Aroma-therapy

Hot Cross Buns

- 1 (.25 ounce) package active dry yeast
- 1/4 cup water
- 4 1/4 cups all-purpose flour
- 1/4 teaspoon salt
- 1/2 cup white sugar
- 1 teaspoon ground cardamom
- 1 1/4 cups lukewarm milk
- 1/2 cup butter, melted
- 1 egg
- 1/4 cup golden raisins (optional)
- 1/4 cup dried cherries (optional)
- 1/4 cup dried cranberries (optional)
- 2 1/2 cups confectioners' sugar
- 1/4 cup milk
- 1 teaspoon almond extract

Instructions:

1. Sprinkle the yeast over the warm water and let stand until dissolved, about 5 minutes.
2. Place the flour, salt, sugar, cardamom, 1 1/4 cups of milk, butter and egg into the bread machine.
3. Pour the yeast mixture on top. Close the lid and set the machine for the Dough setting.

4. If using raisins, dried cherries or dried cranberries, add them at the beep.
5. When the dough has finished, divide into 12 portions and shape into balls. Place them into a greased 9x13 inch baking dish.
6. Cover with plastic wrap and set aside to rise until doubled in size, about 45 minutes.
7. Preheat the oven to 350 degrees F (175 degrees C). Remove the plastic wrap from the rolls.
8. Bake in the preheated oven until golden brown, 20 to 25 minutes.
9. Make frosting by whisking together the confectioners' sugar, 1/4 cup of milk and almond extract until smooth.
10. When the buns are cool, drizzle frosting over them in a cross shape.



Cancer Survivor Workshop

"Fear Not: Learning from Your Cancer"
By Judy Gattis Smith

6 Week Workshop for Cancer Survivors
Led by the author, a cancer survivor and
Christian educator.

Thursdays, April 15 - May 20
10 - 11 am

Duncan Memorial United Methodist Church
201 Henry Street
Ashland, VA 23005

Register: 804-798-7224 (space limited)
Cost: \$30/person, includes book

"Whether you have just received your diagnosis of cancer or have been in remission for many years, you are a cancer survivor.

Though cancer is a devastating experience, it can be a time of personal growth and self-understanding." **Judi Gattis Smith**

"I am very impressed with Judy's expertise, knowledge of the subject matter, and creative ways of leading worship participants to delve into their emotional responses to dealing with cancer. She exhibits a real understanding of the various ways people learn to live with cancer. She offers possibilities for opening doors for cancer survivors to walk through into their own personal room where they can find comfort and courage."

Jean S Stockton
Cancer Survivor and wife of former
Bishop Tom Stockton

GOOD NEWS T-SHIRT

Jesus told his disciples — and us — to go into all the world and preach the good news. Wherever you go, this cool T-shirt will help spark conversations about your faith.

What you need:

- Newspaper
- Cardboard
- Plain white, cotton T-shirt
- Permanent markers
- Goggles (optional)
- Eye dropper
- Rubbing alcohol
- Clothes hanger

What you do:

1. Cover a table with newspaper. (Work outside or in a well-ventilated area.)
2. Place a piece of cardboard inside your T-shirt. (This keeps pen marks from going through to the other side.)
3. With permanent markers, draw a design of large circles, spirals, hearts, etc.
4. Wear goggles while dropping rubbing alcohol onto your designs with an eye dropper. As the alcohol permeates the permanent marker, the color will break up and spread in interesting ways.
5. Hang the shirt to dry.
6. When the shirt is dry, place cardboard inside it again. On the front, write "I have some good news to share with you." You can also write a Bible verse.

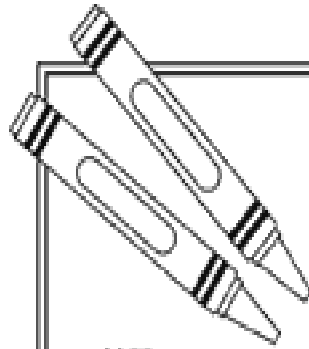

Just for

KIDS

"I am with you always."

Before Jesus ascended into heaven, he encouraged his disciples in the work they had to do. We, too, are Jesus' disciples and should follow his same instructions.

Follow the words in the clouds to find Mark 16:15-16a, *NIV*.

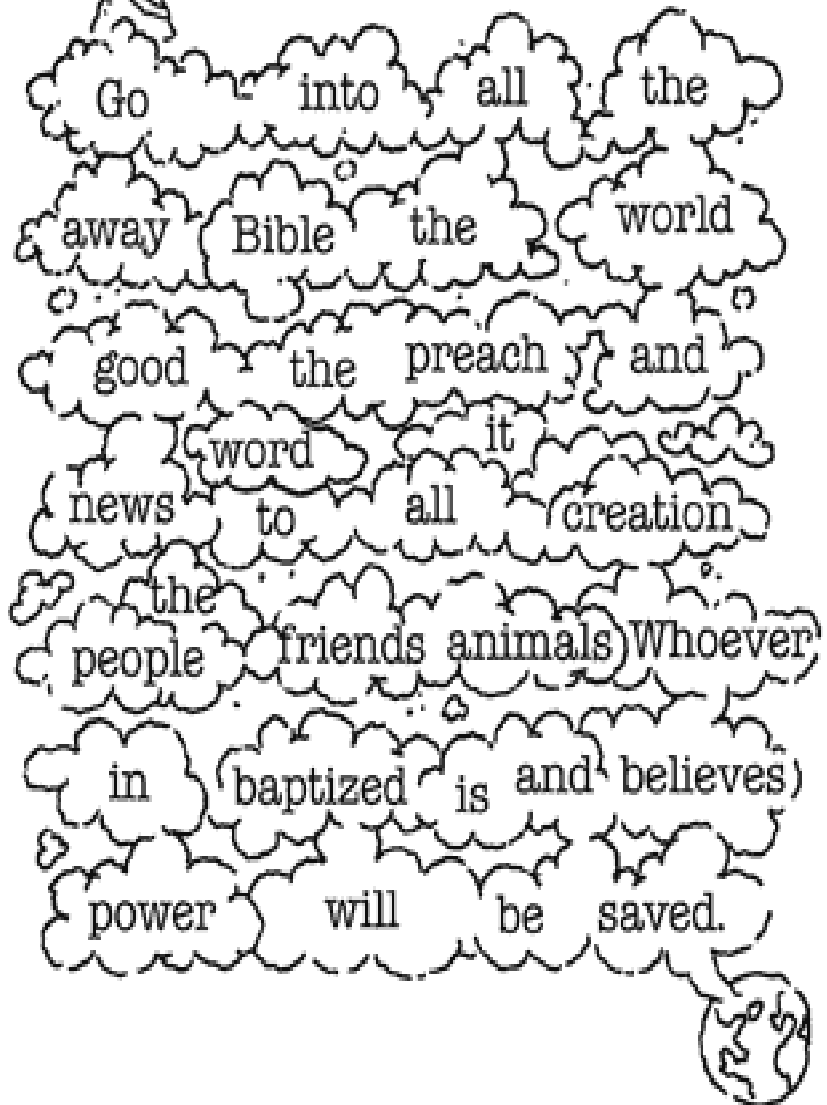





Answer: "Go into all the world and preach the good news to all creation. Whoever believes and is baptized will be saved." (Mark 16:15-16a, *NIV*)

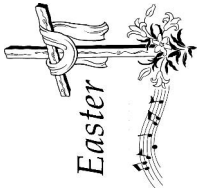

April 2010



Sun	Mon	Tue	Wed	Thu	Fri	Sat
4.  Easter	5 Finance Mtg 7 pm Boy Scouts	6	7 Circles	8 Choir	9 LP @ 7:00 pm 	10 Emmaus Team
11 LP Council Meeting	12 VBS Mtg 7 pm Boy Scouts	13 LP United Methodist Women	14  Fellowship Meals 6:30 pm	15 Choir Cub Scouts	16 Friendship Quilters	17 Friendship Quilters Emmaus Team
18 FunRaisers Bag Lunch Pick-up	19 Boy Scouts	20	21 Cornerstones Prayer Meeting	22 Choir Cub Scouts Census Bureau 8:30 am - 5:00 pm	23	24 Emmaus Team
25	26 Boy Scouts	27 Census Bureau 8:30 am - 5:00 pm	28 Prayer Meeting Census Bureau 8:30 am - 5:00 pm	29 Choir Cub Scouts Census Bureau 8:30 am - 5:00 pm	30 Census Bureau 8:30 am - 5:00 pm	3 Men's Breakfast 

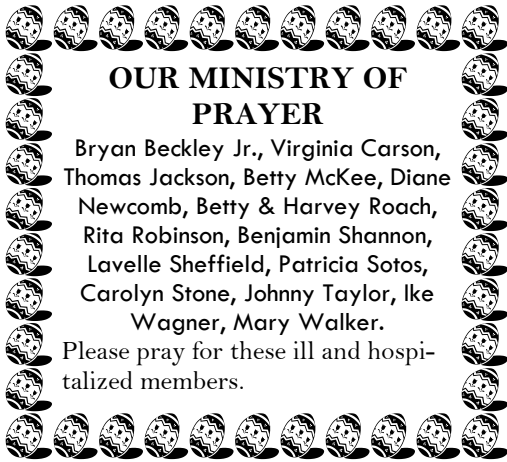

OUR MINISTRY OF PRAYER

Bryan Beckley Jr., Virginia Carson,
Thomas Jackson, Betty McKee, Diane
Newcomb, Betty & Harvey Roach,
Rita Robinson, Benjamin Shannon,
Lavelle Sheffield, Patricia Sotos,
Carolyn Stone, Johnny Taylor, Ike
Wagner, Mary Walker.

Please pray for these ill and hospital-
alized members.



April 2010

**Greenwood United
Methodist Church
April 2010**

10040 Greenwood Road
Glen Allen, VA 23060
Phone: 804-266-5341
Fax: 804-266-2019

9:30 am - Sunday School
11:00 am - Worship

Senior Pastor Dean Pittman
Rev. Mary Ann Googins
Minister of Discipleship

Email: admin@gumcva.org

PASTOR'S HOME

11090 Quail Whistle Drive
Glen Allen, VA 23059
804-262-1628

After School Phone:
804-266-6668

Visit our web site at
www.gumcva.org

**Return Service Requested
Please Expedite**

**NON-PROFIT ORG.
U.S. POSTAGE PAID
Permit # 16
Glen Allen, Va. 23060**

